

OPERATOR'S MANUAL



POWDERSAFE™

DUCTLESS BULK ENCLOSURE

Models:

AC794BE

AC795BE

AC796BE

AirClean® Systems
The Fume Control Experts.

Raleigh, NC 27604 USA

Phone: 919-255-3220 • Toll Free: 800-849-0472 • Fax: 919-255-6120

Website: www.aircleansystems.com • Email: info@aircleansystems.com

CONTENTS

| SECTION | PAGE |
|---|-------------|
| Overview | 3 |
| Technical Specifications | 4 |
| Installation and Assembly | 5 |
| Operating Instructions (for Powders and Particulate) and Alarm Messages | 6 |
| Operating Instructions (for Fumes and Vapors) and Alarm Messages | 7 |
| Airflow Path | 8 |
| Side View with Disposal Port | 9 |
| View of Base with Bag Access and Collar | 10 |
| Controller Instructions | 11 |
| Programming Menus | 11-12 |
| Quick Keys | 13 |
| Maintenance: | |
| • Pre-filters | 14 |
| • HEPA Filters | 15 |
| Options | 16-17 |
| Spare Parts List | 18 |
| Warranty | 19 |
| Shipping Claims | 20 |
| Contact Information | 21 |

OVERVIEW



Bulk Enclosure

AirClean® Systems PowderSafe™ Bulk Enclosures incorporate the airflow characteristics and HEPASafe™ filtration technology of the PowderSafe™ Type B Enclosures while offering the chemical adsorption capability of our ductless fume hoods. The Bulk Enclosures provide effective operator protection from potential exposure to toxic powders, particulate, chemical fumes and vapors. The AirSafe™ automatic safety controller constantly monitors airflow and filter conditions.

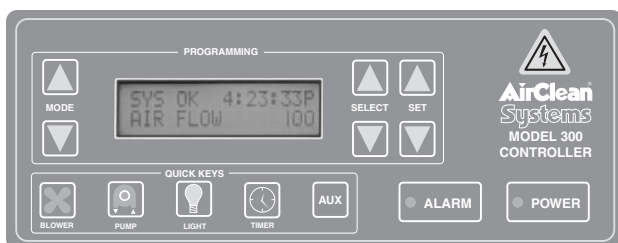

AirSafe™ Automatic Safety Controller

The AirSafe™ automatic safety controller provides operator protection 24 hours a day. Incorporating a combination of airflow monitoring, filter monitoring, and gas detection the AirSafe™ automatic safety controller allows you to breathe easier knowing your safety is being constantly monitored.



Bonded Carbon Filter

Bonded carbon filters produce “no filter dust” normally associated with carbon filtration. In the past, a HEPA “after” filter was required to protect applications from carbon dust. AirClean® Systems has eliminated this problem with “breakthrough bonded carbon technology.” Bonded carbon filters are solid blocks of activated coconut shell carbon, held in a solid and predictable matrix via proprietary binder. The filter has the same life as a granular carbon filter, however, the carbon is much more evenly distributed within the filter, eliminating “dead areas” found in granular carbon filters.



HEPA Filter

High-Efficiency Particulate Air filters are designed to trap toxic powders and fibers associated with a variety of applications.

TECHNICAL SPECIFICATIONS

| SPECIFICATIONS | AC794BE | AC795BE | AC796BE |
|--|---------------------|---------------------|---------------------|
| Physical Dimensions | | | |
| Outside Dimensions | 48"W x 36"D x 54"H | 60"W x 36"D x 54"H | 72"W x 36"D x 54"H |
| Inside Dimensions | 42"W x 29"D x 35"H | 59"W x 29"D x 35"H | 71"W x 29"D x 35"H |
| Weight, including filters | | | |
| Airflow Characteristics | | | |
| Low Airflow Alarm | AirSafe™ | AirSafe™ | AirSafe™ |
| Volume of Filtered Air | 500 CFM | 500 CFM | 660 CFM |
| Linear Face Velocity | Variable | Variable | Variable |
| Electrical | | | |
| Voltage | 110 V or 220 V | 110 V or 220 V | 110 V or 220 V |
| Current | 5.6 A / 2.8 A | 5.6 A / 2.8 A | 5.6 A / 2.8 A |
| Power Consumption | 616 W | 616 W | 616 W |
| Operation | | | |
| Speed Selection | Auto / Manual | Auto / Manual | Auto / Manual |
| Construction | | | |
| Front Panel | Powder Coated Steel | Powder Coated Steel | Powder Coated Steel |
| Base and Sides | Polypro | Polypro | Polypro |
| Sash Material | Polycarbonate | Polycarbonate | Polycarbonate |
| Pre-filter ¹ | | | |
| Type | ACFPRE1 | ACFPRE1 | ACFPRE1 |
| Dimensions | 12" x 24" x 1" | 12" x 24" x 1" | 12" x 24" x 1" |
| Requirements | 3 | 4 | 4 |
| Primary HEPA Filter ² | | | |
| Type | ACFHEPA | ACFHEPA | ACFHEPA |
| Dimensions | 12" x 24" x 3" | 12" x 24" x 3" | 12" x 24" x 3" |
| Requirements | 3 | 4 | 4 |
| Secondary HEPA Filter ³ | | | |
| Type | ACFHEPA | ACFHEPA | ACFHEPA |
| Dimensions | 12" x 24" x 3" | 12" x 24" x 3" | 12" x 24" x 3" |
| Requirements | 3 | 4 | 4 |
| Bonded Carbon Filter ⁴ (Optional) | | | |
| Type | (Application Based) | (Application Based) | (Application Based) |
| Dimensions | 12" x 24" x 3" | 12" x 24" x 3" | 12" x 24" x 3" |
| Requirements | 3 | 4 | 4 |

NOTE 1 - Your enclosure is shipped with the prefilter(s) attached to the inside of the enclosure. AirClean® Systems prefilters are filterete electrostatic particulate filters with 65% efficiency for particulate down to 0.5 microns in diameter (PAO test). The pre-filter must be checked on a scheduled basis. Refer to the "MAINTENANCE" section of this manual.

NOTE 2 - Your AirClean® Systems enclosure was shipped with the Primary and Secondary HEPA filters installed.

NOTE 3 - If your application is particulate-based only, a HEPA filter is required. The HEPA filters **will not protect the operator from any fumes.**

NOTE 4 - Bonded carbon filters are required for chemical-based applications or when trying to contain aromas from powders. The bonded carbon filter will not aid in the containment of particulate.

INSTALLATION AND ASSEMBLY

SHIPMENT CONTENTS

- AirClean® Systems PowderSafe™ enclosure complete
- Operator's Manual
- Power Cord
- Optional Equipment (if ordered)

INSTALLATION AND ASSEMBLY INSTRUCTIONS

Caution: This enclosure should not be installed near doors, windows or air conditioning/ heating/ ventilation systems. Air must be allowed to circulate freely around the enclosure. Allow at least 3" between the top of the enclosure and any overhead cabinets or shelving for adequate exhausting.

- A. If ordered, assemble the mobile cart. Installation instructions are included with the cart and in the "OPTIONS" section of this manual.
- B. Place the enclosure on the cart or the counter.
- C. Remove the prefilter for inspection before use. Refer to the "MAINTENANCE" section of this manual for complete instructions.
- D. Connect the supplied power cord to the unit and to the power outlet. Flip the main power switch of the unit above the power inlet module.
(Power cord connection located on the top of the enclosure)

This will activate the main power. The screen on the controller should light up and display the time and the date.

- E. Press the "Power" button on the controller. This will activate the controls for the enclosure. If the blower does not activate press the quick key labeled, "Blower". If the blower still does not activate contact the technical support staff at the factory. Direct Dial 919-255-3220 or 800-849-0472. Monday-Friday 8:00-5:00 PM EST.

OPERATING INSTRUCTIONS - POWDERS & PARTICULATE

The following operating instructions are specific for containment of powders and particulate.

NOTE: Ensure that the INSTALLATION AND ASSEMBLY INSTRUCTION steps have been completed.

- A. To operate the enclosure:
 1. Before use, ensure that you are not using an incompatible substance within the enclosure. With a HEPA filter, use only powders in the enclosure. For other substances, please call our office to verify compatibility before use (in this case, your filter may have another model number). Direct Dial 919-255-3220 or 800-849-0472. Monday-Friday 8:00-5:00 PM EST.
 2. Connect the supplied power cord to the unit and to the power outlet. Flip the switch on the back of the unit above the power inlet module. This will activate the main power. The screen on the controller should light up and display the time and the date. Allow the enclosure to run for 5 minutes before beginning your application.
 3. Perform any part of your process that involves powders or particulate inside your enclosure.
- B. When working within the enclosure, keep the front sash down and perform your procedure in the center to rear of the enclosure.
- C. If the low airflow alarm sounds and/or lights up, the pre-filter or HEPA filter may be clogged.
- D. When this happens refer to the “MAINTENANCE” section of this manual.

REMEMBER: Following the instructions assures better protection of the operator and the environment, and extends the life of the enclosure and filter. Correct use of the enclosure is the responsibility of the operator!

ALARM MESSAGES

The alarms that are built into the system are maintenance related. They are designed to tell the operator about conditions that may affect the operation of the enclosure and decrease its performance.

- **ALARM → CHG FILT** - The change filter alarm is a chronological timed alarm that turns on about two weeks before the HEPA filter should be changed. It serves as a reminder to change the filter before it becomes blocked.
- **ALARM → FILT BP** - the BP alarm comes on when either the prefilter or the HEPA filter becomes dirty and the enclosure requires immediate filter maintenance.
- **ALARM → LOW AIRFLOW** - The Low Airflow alarm comes on when the face velocity drops below the pre-set limit.

OPERATING INSTRUCTIONS - FUMES & VAPORS

The following operating instructions are specific for containment of fumes and vapors.

NOTE: Ensure that the INSTALLATION AND ASSEMBLY INSTRUCTION steps have been completed.

- A. To operate the enclosure:
 1. Before use, ensure that you are not using an incompatible substance within the enclosure. With a bonded carbon filter, use only liquids in the enclosure. For other substances, please call our office to verify compatibility before use (in this case, your filter may have another model number). Direct Dial 919-255-3220 or 800-849-0472. Monday-Friday 8:00-5:00 PM EST.
 2. Connect the supplied power cord to the unit and to the power outlet. Flip the switch on the back of the unit above the power inlet module. This will activate the main power. The screen on the controller should light up and display the time and the date. Allow the enclosure to run for 5 minutes before beginning your application.
 3. Perform any part of your process that involves liquids inside your enclosure.
- B. When working within the enclosure, keep the front sash down and perform your procedure in the center to rear of the enclosure.
- C. If the low airflow alarm sounds and/or lights up, the prefilter or bonded carbon filter may need to be changed.
- D. When this happens refer to the “MAINTENANCE” section of this manual.
- E. If the GAS DET alarm sounds, stop your process and call technical support immediately at (800)849-0472.

REMEMBER: Following the instructions assures better protection of the operator and the environment, and extends the life of the enclosure and filter. Correct use of the enclosure is the responsibility of the operator!

ALARM MESSAGES

The alarms that are built into the system are maintenance related. They are designed to tell the operator about conditions that may affect the operation of the enclosure and decrease its performance.

- **ALARM → CHG FILT** - The change filter alarm is a chronological timed alarm that turns on about two weeks before the bonded carbon filter should be changed. It serves as a reminder to change the filter before it becomes blocked.
- **ALARM → GAS DET** - The gas detector alarm comes on when breakthrough is detected.
- **ALARM → LOW AIRFLOW** - The low airflow alarm comes on when the face velocity drops below the pre-set limit.

AIRFLOW PATH

Bulk Enclosure

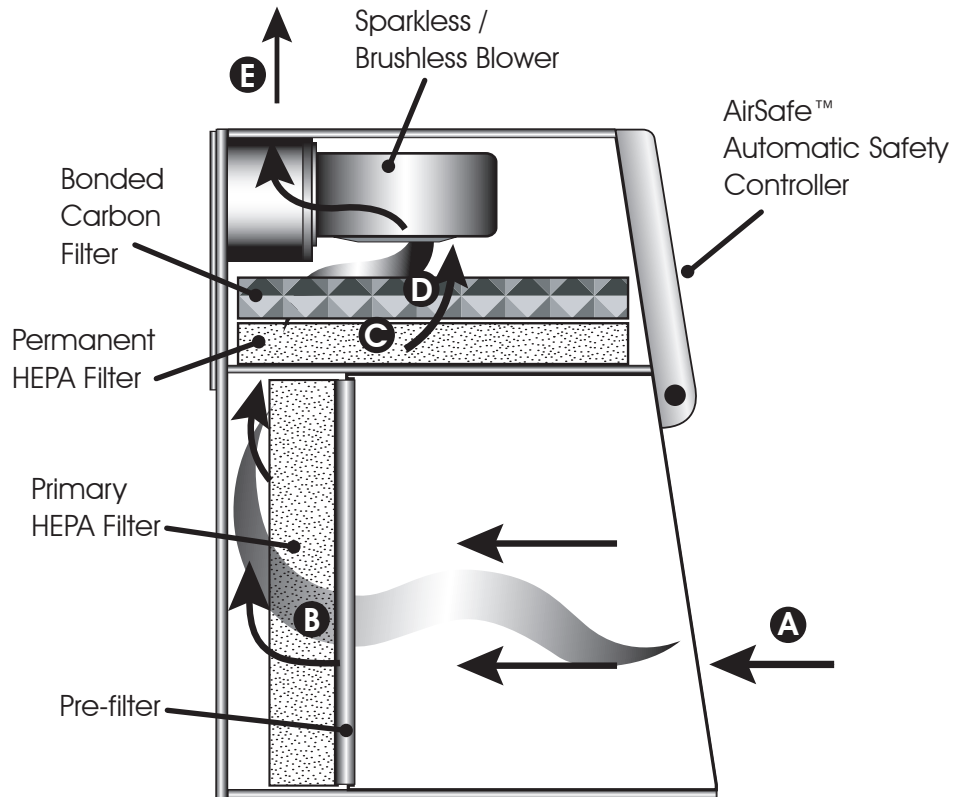

How the PowderSafe™ Bulk Enclosure works:

- 1) Air enters at "A" in an even horizontal laminar flow.
- 2) Contaminated air enters "B" where particulate is removed via electrostatic pre-filtration and HEPA filtration.
- 3) Particulate free air moves upward to "C" where it enters the HEPASafe™ filtration area. This filtration is only challenged with particulate during primary filter changeout.
- 4) Particulate free air then passes into "D", the deep carbon filter bed, where dangerous chemical fumes and vapors are removed.
- 5) Clean air is then exhausted at "E" for return to the laboratory.

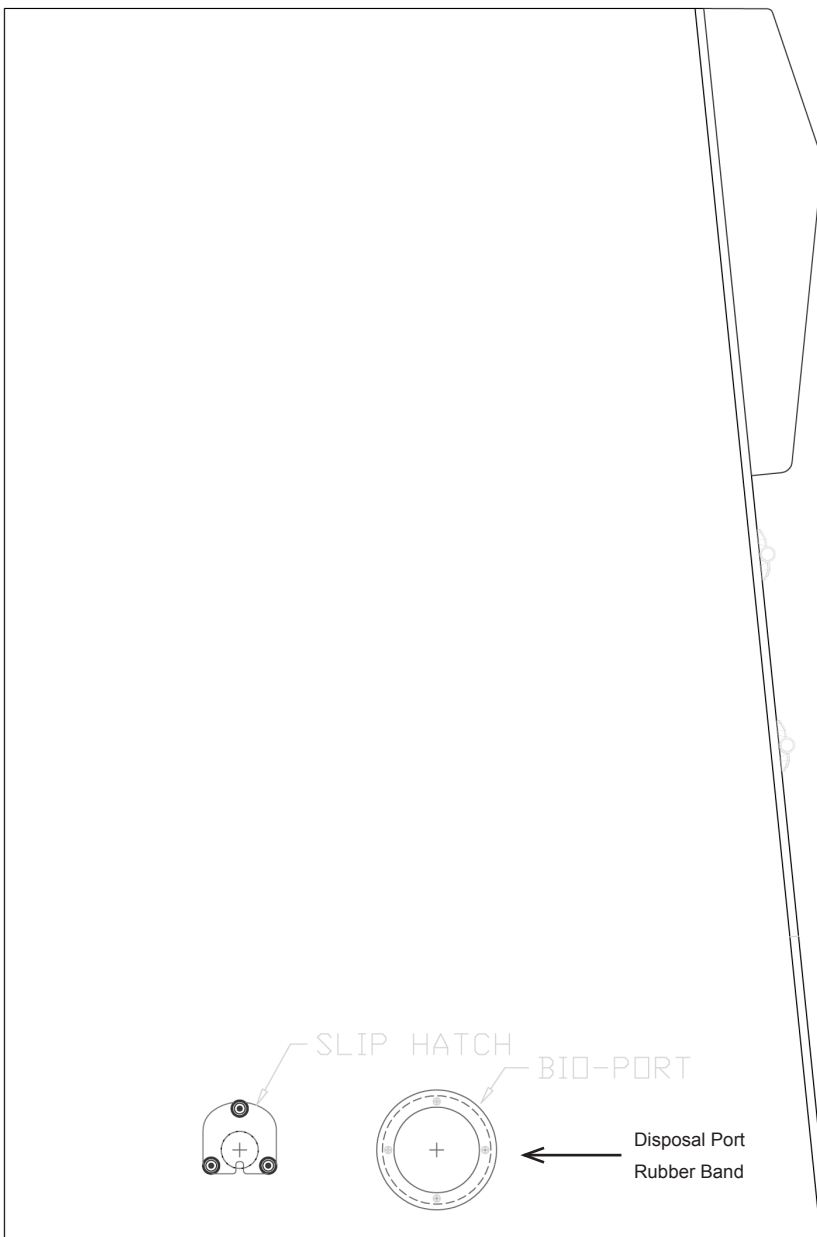

LEFT SIDE VIEW

AIRCLEANSYSTEMS

SCALE: NTS
DATE: 08/24/07

PROPRIETARY AND CONFIDENTIAL
THE INFORMATION CONTAINED IN THIS DOCUMENT IS THE
SOLE PROPERTY OF AIRCLEANSYSTEMS. ANY
REPRODUCTION IN PART OR AS A WHOLE WITHOUT
WRITTEN PERMISSION IS PROHIBITED.

DRAWN BY: JAMES R DOBBYN
REVISED:

AC700 SERIES BULK ENCLOSURE

P 2 of 4

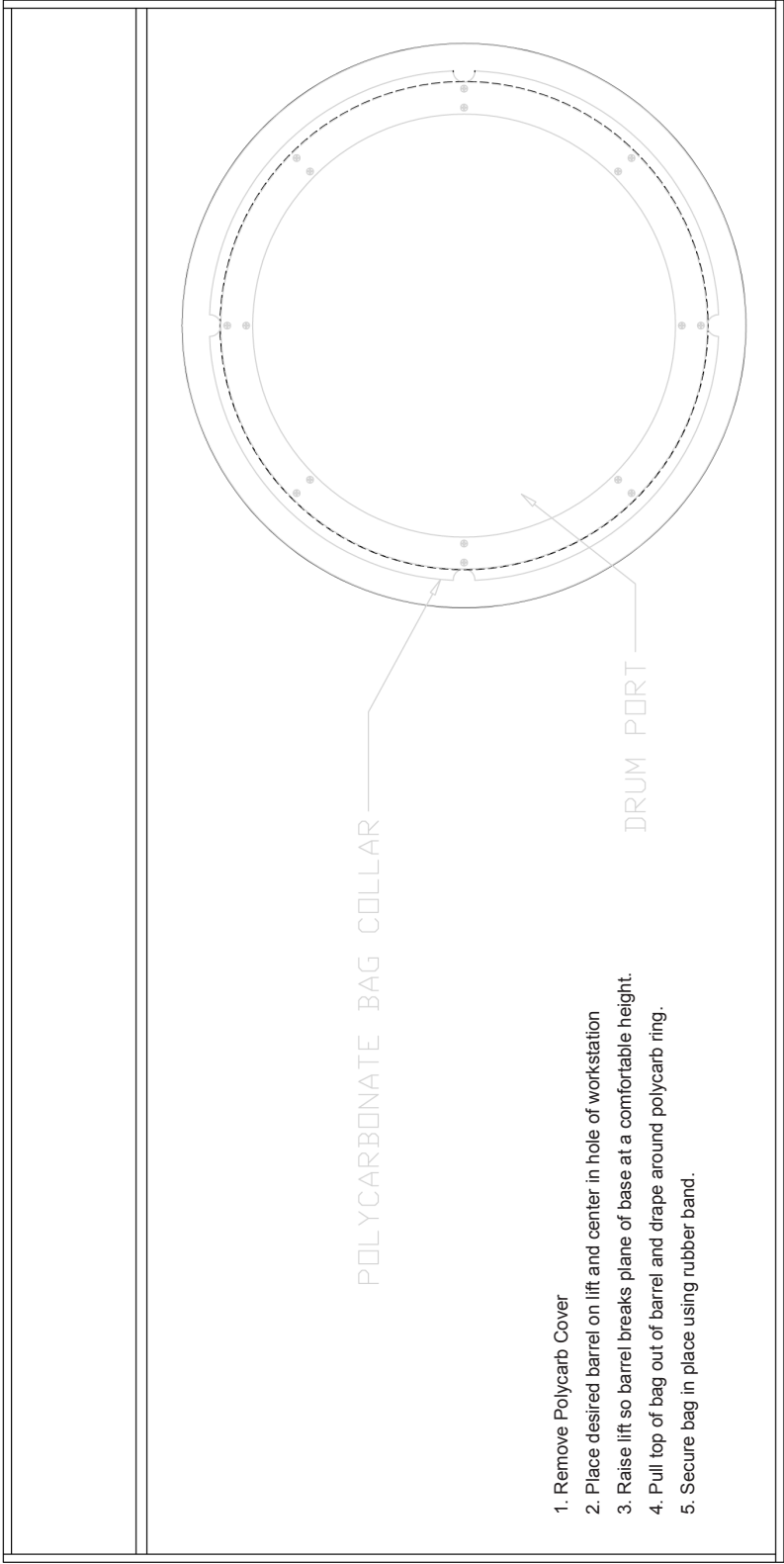

PLAN VIEW AT BASE WITH
POLYCARB BAG COLLAR

| | | | |
|-----------------------------|----------------|---|--------------------------|
| AIRCLEANSYSTEMS | SCALE: NTS | <small>PROPRIETARY AND CONFIDENTIAL THE INFORMATION CONTAINED IN THIS DOCUMENT IS THE SOLE PROPERTY OF AIRCLEANSYSTEMS. ANY REPRODUCTION OR TRANSMISSION OF THIS DOCUMENT WITHOUT WRITTEN PERMISSION IS PROHIBITED.</small> | DRAWN BY: JAMES R DOBBYN |
| | DATE: 08/24/07 | | REVISED : |
| AC700 SERIES BULK ENCLOSURE | | P 4 of 4 | |

CONTROLLER INSTRUCTIONS

PROGRAMMING KEYS

The AirSafe™ Automatic Safety Controller is the first of its kind on the market. This breakthrough was designed to give the user a variety of options with the ease of fingertip control. The controller board consist of 13 keys, each with a specific function:



MODE Allows the operator to move between different program screens.



SELECT Allows movement within each program screen. The user modifiable portions of the screen will blink.



SET Allows operator to adjust the following user definable settings:

- Face velocity
- Lab event timer
- Time/Date
- Gas detection

* All other settings are factory preset and should not be changed.



ALARM Allows deactivation of the audible alarm but keeps the visible alarm armed.



POWER Turns on/off power to the controller and its keys. This DOES NOT cut off power to the entire enclosure. (The main power switch is located above the power inlet on the back, right-hand side of the enclosure.)

PROGRAMMING MENUS

MAIN MENU - Displays the time and date when the main power is on and the controller power is off. When controller power is activated the screen will display one of the following and may be changed by pressing the “Select” down arrow key:

- Airflow Monitor (Measured in Linear Feet per Minute)
- Lab Event Timer (Preset at 20 minutes)
- Current HEPA filter reading (measured in back pressure - BP)
- Current GAS DET reading (If a bonded carbon filter is installed)

NOTE: Activating the Lab Event Timer (by menu or Quick Key) will automatically switch the main menu to display the timer countdown. To switch the display back to the Airflow Monitor, just toggle with the “Select” up arrow key.

PROGRAMMING MENUS

BLOWER CONTROL – This menu is preset at the factory to meet O.S.H.A. face velocity standards while in AUTOMATIC mode. From this screen you can:

- Turn the blower on/off.
- Switch from automatic to manual blower speed based on the application.
- Change the output of the blower.

TIMER – This menu allows the operator to turn the timer on/off and to program an appropriate event time. Once the operator has programmed the desired time, the Timer can be activated by touching the Timer Quick Key on the front of the controller.

TIME/DATE – The operator can change displayed time and date.

ALARM SETTINGS – All alarm points for face velocity, HEPA filter and gas detection have been preset by the manufacturer and should not be altered.

ALARM SCREEN – Allows the operator to turn the low airflow, HEPA, and gas alarms on/off in this screen. This controls both the audible and the visible alarms. If the operator turns off the alarm in this screen, nothing (audible or visible) will alert you if the airflow is below the selected face velocity, the HEPA filter is clogged, or the bonded carbon filter fails.

NOTE: The operator can deactivate the audible alarm, when it sounds, by touching the alarm button on the controller. The visible alarm will still work.

FILTER – This menu shows the serial number and the purchase date of the filter. For every new filter installed, a new filter serial number must be entered. Refer to the “MAINTENANCE” section for complete instructions. The first filter serial number has already been entered for you prior to shipment.

BLOWER HOURS – Displays the hours and minutes that the blower has been active.

GAS DETECTOR – (for carbon enclosures only) A solid state hydrocarbon detector warns the user of filter breakthrough. Alarms are audible and visible.

ADDITIONAL INFORMATION

- Keep the right hand side of the unit away from the wall and turbulent places. Never install enclosures near doorways or high-traffic areas.
- To avoid confusion, each alarm has a distinctive sound and will flash what the problem is on the display screen.
- A few minutes are needed for the airflow sensor to warm up, stabilize, and settle at the correct airflow speed.
- Unless the operator turns the blower off (by Quick key or in the blower menu) before turning the power off, the blower will automatically come on each time the operator activates the unit.
- Anything the operator changes within the program is automatically saved.
- Allow each enclosure to run five minutes, before use, to stabilize the environment.

QUICK KEYS



Figure 6, AirSafe™ automatic safety controller layout.

| | |
|--|---|
| | BLOWER - Default screen will continuously display face velocity while blower is activated. |
| | PUMP - Inactive key for enclosure. |
| | LIGHT - One touch to enable fluorescent light, if installed. |
| | TIMER - User definable lab event timer. |
| | AUX - Inactive key for enclosure. |

• All other settings are factory pre-set and should not be changed.

MAINTENANCE

Pre-filters

Pre-filters should be checked each month. In most cases, they should be changed every 1 to 3 months. Prefilter replacement is required when discoloration of the prefilter occurs or when the low airflow alarm comes on. See the “PRE-FILTER CHECK/REPLACEMENT” section of this manual for complete instructions.

HEPA Filters

The HEPA filter must be changed at least every two years. See the “FILTER REPLACEMENT” section of this manual for complete instructions.

The HEPA filter must be changed every two years or whenever it is clogged. The frequency with which the filter must be changed depends upon usage. OSHA and the American Conference of Government Industrial Hygienists (ACGIH) have published guidelines for Threshold Limit Values (TLV's) of exposure to chemicals and particulate. Local regulations may also contain specific TLV's. It is the express responsibility of the user to follow these regulations.

If the level of the substance being used exceeds the published TLV's prior to the annual change date, the HEPA filter must be changed. If the filter is changed prior to the annual date, it should be changed every two years from this new date.

Pre-filter Check / Replacement

A. To check the Pre-filter:

1. Look through the sash to the inside of your unit. The pre-filter and pre-filter grid are located at the back of the unit.
2. Look through the slats on the pre-filter grid. If the prefilter is discolored (the original color is green), replacement is needed.

B. To replace the Pre-filter:

1. Don the proper PPE for handling the substance that have been used inside the hood (refer to the MSDS sheets).
2. Turn the unit on and make sure that the blower is running.
3. Place an appropriate poly bag on the base of the enclosure. You will place the saturated pre-filter inside the bag and seal it before removing it from the hood.
4. Remove the 4 black knobs or 6 polypropylene clips that hold the prefilter grid in place. This will expose the clogged pre-filter. Do not remove the pre-filter from the hood!
5. Remove the pre-filter from the pre-filter grid and place it inside the poly bag. Wipe any residue off of the pre-filter grid and base of the enclosure. Place the rag inside the bag with the pre-filter and seal the bag. Dispose of the pre-filter in accordance with your local guidelines for the substances that have been used inside the hood.
6. Inspect the HEPA filter for blockage. If replacement is needed, refer to the “FILTER REPLACEMENT” Type B, sub-section of this manual for complete instructions.
7. Place the new pre-filter into the pre-filter grid and secure into place with the 4 black knobs or 6 polypropylene clips.
8. Dispose of your PPE in accordance with your local guidelines for the substances that have been used inside the hood.

MAINTENANCE

FILTER REPLACEMENT

A. To remove the spent ACFHEPA filter:

1. Turn the unit on and make sure that the blower is running. The safety filter, located in the top of the workstation, will protect you from any residual powders that might come off of the saturated primary HEPA filter while replacing it.
2. Place 2 appropriate poly bags on the base of the workstation. You will place the saturated prefilter and HEPA filter inside the bag and seal it before removing it from the hood.
3. Don the proper PPE for handling the substance that have been used inside the hood (refer to the MSDS sheets). Remove the 4 black knobs holding the prefilter grid in place. This will expose the saturated pre-filter. **DO NOT REMOVE THE PRE-FILTER FROM THE HOOD!**
4. Remove the pre-filter from the pre-filter grid and place it inside the poly bag. Wipe any residue off of the pre-filter grid and base of the workstation. Place the rag inside the bag with the pre-filter and seal the bag.
5. With a small wrench, remove the $\frac{1}{4}$ - 20 hex nuts and remove the filter hold down.
6. Place the spent HEPA filter into the second poly bag. Wipe any residue off of the filter hold down frame and any other obvious areas. Place the second rag into the bag and seal the bag. Dispose of both bags in accordance with your local guidelines for the substances that have been used inside the hood.

B. To install the new ACFHEPA filter:

1. Remove the ACFHEPA from the packaging. Visually inspect the HEPA filter for rips in the filter media.
2. Place the filter into the filter grid with the gasket and screen side facing away from you.
3. Place the filter hold down frame over the HEPA filter and secure it with the hex nuts.
4. Place the new pre-filter into the pre-filter grid and secure into place with the 4 black knobs.
5. Dispose of your PPE in accordance with your local guidelines for the substances that have been used inside the hood.

Check the display screen to assure that the enclosure is functioning properly:

1. If the Low Airflow Alarm is not activated, proceed to use the enclosure.
2. If the Low Airflow Alarm is activated, contact our Technical Support Department at (800)849-0472. Direct dial (919)255-3220. Monday - Friday 8:00AM - 5:00PM EST.

OPTIONS

AIRCLEAN® SYSTEMS CART ASSEMBLY INSTRUCTIONS

Model ACA1011 and ACA1039

Your AirClean® Systems Cart is shipped with the following components:

- | | |
|--|--|
| 4 - Cross pieces | 8 - 1¼" washers (cross piece washers) |
| 2 - End pieces | 4 - 1¾" x ¼" Phillips head bolts (enclosure bolts) |
| 4 - ⅜" washers (enclosure bolt washers) | 4 - Casters |
| 8 - 2" x ¼" Phillips head bolts (cross piece bolts) | |

ASSEMBLY OF CART

1. Locate a cart end piece and one cart cross piece. Place one ⅜" washer on to a 2" phillips head bolt.
2. Starting with hole one on the cart end piece place washer and bolt through the hole and into the threaded receiver of the cart cross piece. Hand-tighten only until cart is completely assembled.
3. Repeat steps above for holes 2 and 3.
4. For standard setup complete assembly using hole 4. For seated use complete assembly using hole 5.
5. Tighten all bolts completely.
6. Installation of casters should be per illustration on page 29.

MOUNTING OF ENCLOSURE TO ASSEMBLED CART

1. Place enclosure on assembled cart with front of enclosure and locking casters on the same side.
2. Locate threaded inserts in base of enclosure. Align inserts with mounting holes located on the top of the cart end pieces.
3. Place one of the 1¼" washers on each 1¾" Phillips head bolt.
4. Insert bolt and washer into mounting holes on cart and into the threaded receiver in the base of the enclosure. Hand-tighten only.
5. Repeat this process for all four mounting inserts.

Note: DO NOT OVER-TIGHTEN! Over-tightening will pull the threaded inserts out of the polypropylene base.

CART COMPONENTS

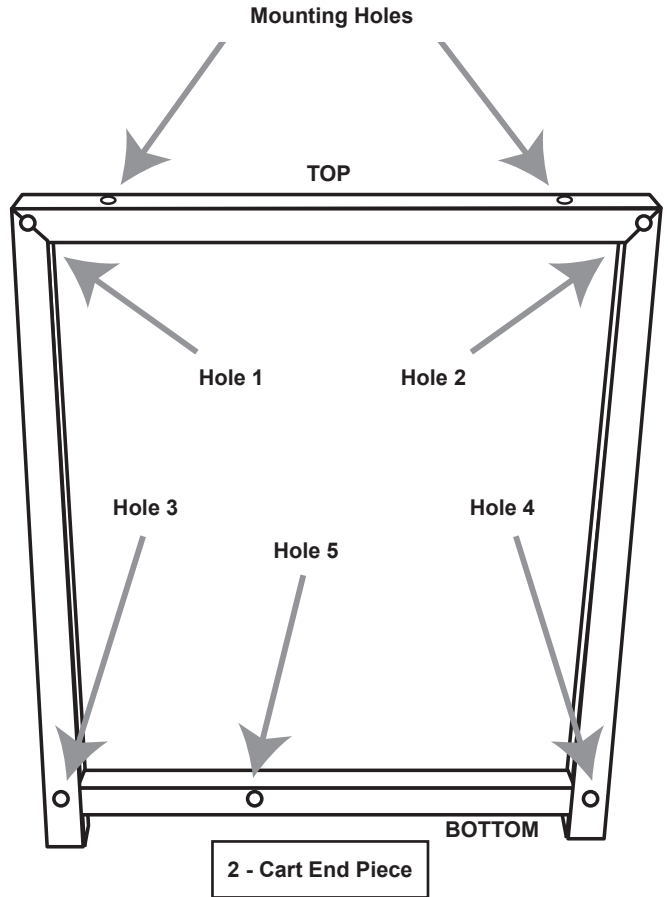
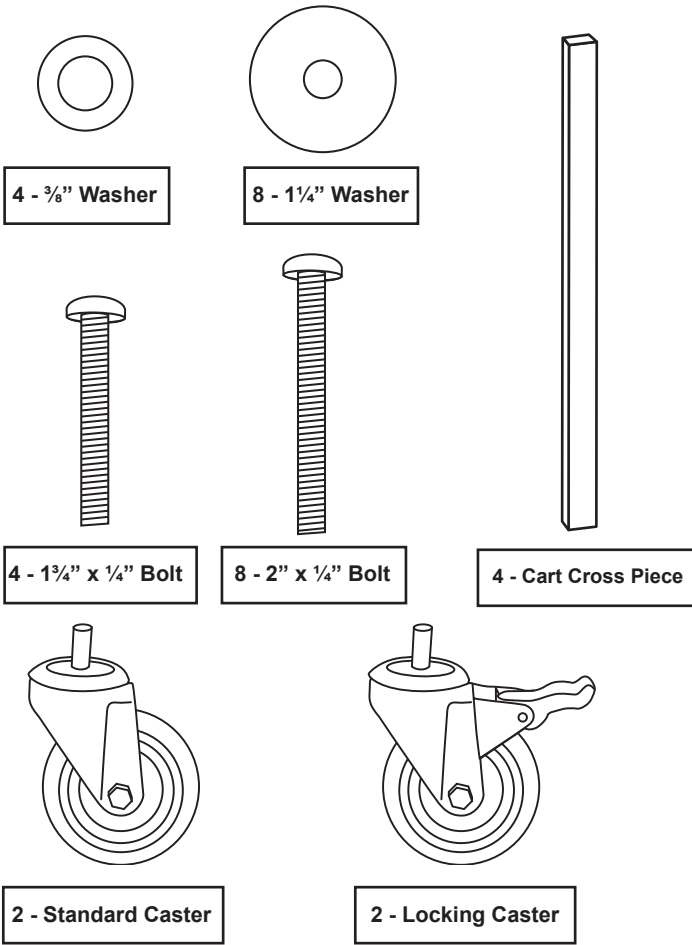

ASSEMBLED CART CONFIGURATIONS

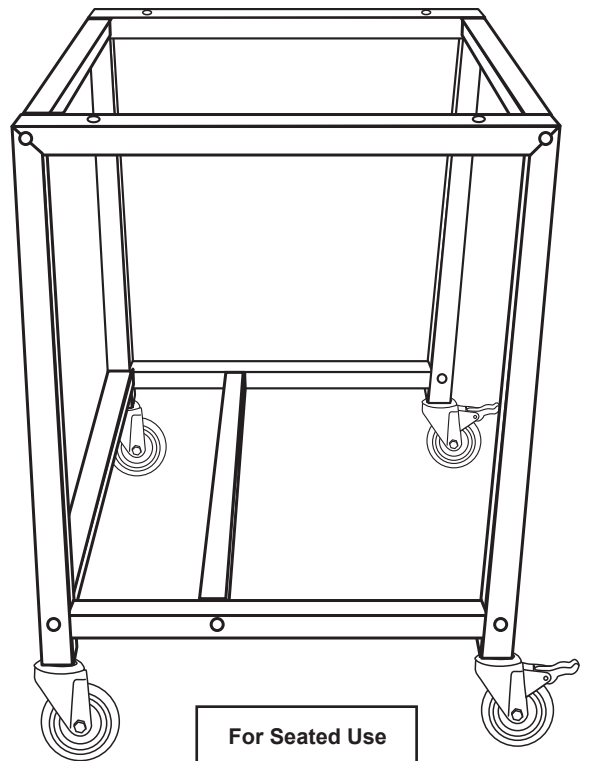
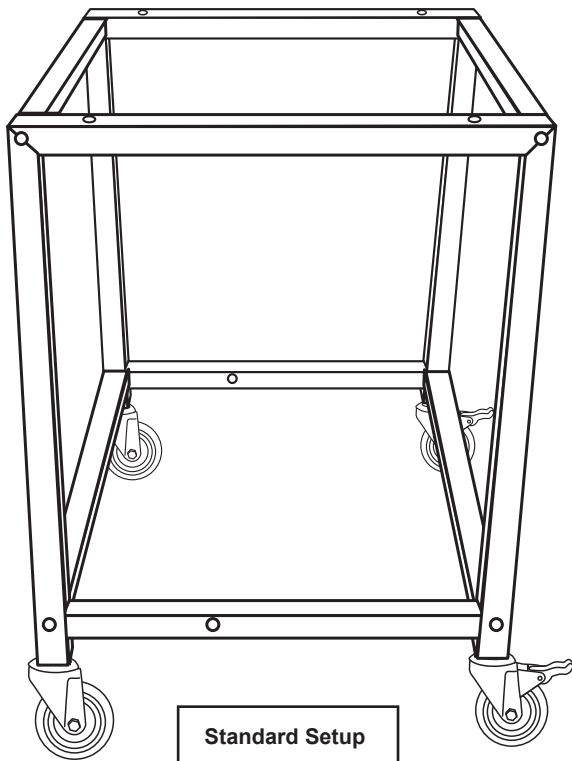

SPARE PARTS LIST

| CATALOG NO. | DESCRIPTION | AC794BE | AC795BE | AC796BE |
|-------------|--|---------|---------|---------|
| 06-50480 | Ball Stud 10mm | 4 | 4 | 4 |
| 10-52517 | Capacitor - 17.5 μ F | 2 | 2 | - |
| 10-50805 | Capacitor - 20 μ F | - | - | 2 |
| 10-52880 | Chip Controller | 1 | 1 | 1 |
| 10-52259 | Fan - G2E140 | 2 | 2 | - |
| 10-50268 | Fan - G2E146 | - | - | 2 |
| 10-51335 | Fluorescent Display | 1 | 1 | 1 |
| 10-51495 | Fluorescent Fixture 20w | 1 | - | 2 |
| 10-51517 | Fluorescent Fixture 30w | - | 1 | - |
| 10-50428 | Fuse - 6.3a 250V Slo-Blo [®] | 1 | 1 | 1 |
| 06-50481 | Gas Strut 60# | 2 | - | 2 |
| 06-51087 | Gas Strut 90# | - | 2 | - |
| 06-50012 | Hinge - Door Positioning | 6 | 8 | 12 |
| 06-50053 | Hinge - Medium Black | 3 | 4 | 5 |
| 11-52756 | Keypad w/shielded cable model (touchpad) | 1 | 1 | 1 |
| 06-50422 | Knob - Round Knurled 1 w/tall hub | 3 | 4 | 5 |
| 10-50169 | Power Entry Module | 1 | 1 | 1 |
| 77-53450 | PCB Assembly AC1500 Controller Board | 1 | 1 | 1 |
| 77-53451 | PCB Assembly 315 Airflow Sensor | 1 | 1 | 1 |
| 06-51371 | Plug Dome 0.75 Blk | 2 | 2 | 2 |
| 01-52700 | Power Cord | 1 | 1 | 1 |

WARRANTY

AirClean® Systems is committed to providing our customers with quality equipment and service after the sale. We, therefore, request that you take a moment to fill out the Warranty Registration Card so that we may know your location as well as some of the reasons that prompted you to purchase our product. To activate the limited warranty on your product, please complete the Warranty Registration Card attached with your shipment, and return to AirClean® Systems.

AirClean® Systems provides a warranty on all parts and factory workmanship. The warranty includes areas of defective material and workmanship, provided such defect results from normal and proper use of the equipment.

The warranty for all AirClean® Systems products will expire one year from date of shipment from AirClean® Systems, except the following:

- DrySafe™ Forensic Evidence Drying Cabinets carry a two-year warranty from date of shipment.
- CyanoSafe™ Cyanoacrylate Fuming Chambers carry a two-year warranty from date of shipment.

This limited warranty covers parts and labor, but not transportation and insurance charges. In the event of a warranty claim, contact AirClean® Systems or the dealer who sold you the product. If the cause is determined to be a manufacturing fault, the dealer or AirClean® Systems will repair or replace all defective parts to restore the unit to operation. Under no circumstances shall AirClean® Systems be liable for indirect, consequential, or special damages of any kind. This statement may be altered by a specific published amendment. No individual has authorization to alter the provisions of this warranty policy or its amendments. Lamps and filters are not covered by this warranty. Damage due to accidental breakage is also not covered.

NOTE: Do not return any materials without authorization from AirClean® Systems. Products returned without prior authorization will not be accepted. AirClean® Systems and its dealers are not responsible for shipping damage. The recipient must file claims directly with the freight carrier. If authorization has been received to return this product, by accepting this approval, the user assumes all responsibility and liability for biological and chemical decontamination and cleansing. AirClean® Systems reserves the right to refuse delivery of any products which do not appear to have been properly cleaned and/or decontaminated prior to return. Please see additional Shipping Claims on Page 24.

IMPORTANT: Locate Warranty Registration Card. Complete and return to activate the warranty on the enclosure.

SHIPPING CLAIMS

If a shipment is received with visible damage, be certain to make a notation on the delivering carrier's receipt and have their agent confirm the damage on your receipt. Otherwise, the damage claim may be refused.

If concealed damage or pilferage is discovered, notify the carrier immediately and retain the entire shipment intact for inspection. Interstate Commerce Commission rules require that the claim be filed with the carrier within 15 days of delivery.

NOTE: Do not return any materials without authorization from AirClean® Systems. Products returned without prior authorization will not be accepted. AirClean® Systems and its dealers are not responsible for shipping damage. The recipient must file claims directly with the freight carrier. If authorization has been received to return this product, by accepting this approval, the user assumes all responsibility and liability for biological and chemical decontamination and cleansing. AirClean® Systems reserves the right to refuse delivery of any products which do not appear to have been properly cleaned and/or decontaminated prior to return.

CONTACT INFORMATION

If you have any questions that are not addressed in this manual, or if you need technical assistance, please contact AirClean® Systems at 800-849-0472, between the hours of 8:00 AM and 5:00 PM EST.

AirClean® Systems mailing address:

AirClean® Systems
3248 Lake Woodard Drive
Raleigh, NC 27604

Phone: 919-255-3220
Toll Free: 800-849-0472
Fax: 919-255-6120

Visit AirClean® Systems on the Internet at: <http://www.aircleansystems.com>

Email AirClean® Systems at: info@aircleansystems.com

MODEL NO.

- AC794BE
- AC795BE
- AC796BE

SERIAL NO.

AC794BE _____

AC795BE _____

AC796BE _____

FILTER INFORMATION

MAIN FILTER(S) INSTALLED

ACF _____

ACF _____

PRE-FILTER INSTALLED

ACF _____

AirClean[®]Systems

The Fume Control Experts.

Raleigh, NC 27604

Phone: 919-255-3220 Toll Free: 800-849-0472 Fax: 919-255-6120

E-mail: info@aircleansystems.com

* Product designs are subject to change without notice.

© 2013 AirClean[®] Systems, Inc.

#ACOM1207PS-BE rev1